

**Phase-angle controller for vibratory feeders**

**REOVIB R15 / 469**

Enclosed version (IP 54)

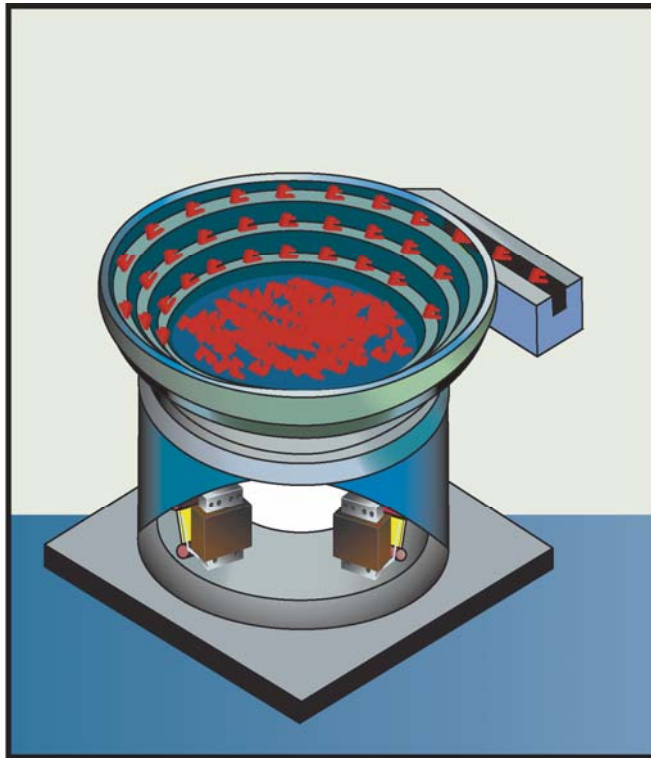
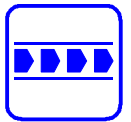

- Mains voltage compensation
- Output frequency 50/100 Hz or 60/120 Hz
- Setpoint via potentiometer, 0...10 VDC or 0(4)...20 mA
- Enable input 24 VDC or contact
- Adjustable soft start
- Amplitude regulation possible
- Status relay

# Phase-angle controller for vibratory feeders

## REOVIB R15 / 469

The REOVIB R15/469 is a range of units used to control the throughput of vibratory feeders working with a magnetic drive. The power is regulated by thyristors using the phase-angle principle.

The setpoint is adjusted by means of a potentiometer, a control voltage or a control current. The internal trimmer pots „Umin“ and „Umax“ are used to adapt to the specific feeder requirements. An enable input is provided for switching the unit from supervisory systems such as a PLC.

Each controller is fitted with a soft start to prevent current surges when the unit is switched on. The units work as regulators, whereby either the output voltage or the amplitude of the feeder is kept constant. When using the unit as amplitude regulator, it is necessary to place a sensor on the feeder to detect the amplitude or the acceleration (for example the sensor type REOVIB SW 07). An internal switch enables the selection of the operating mode (output voltage regulation or amplitude regulation). A status relay is available as an option. The relay switches when there is no output voltage or no actual value signal from the sensor.

The internal semiconductors are short-circuit protected by an integrated fuse. The unit is supplied with a mains switch, an input fuse and an input cable.

Type:	REOVIB R15/469
ID-No.:	230 V/ 46914 400 V/ 46915
Supply voltage:	230 V + 6 % -10 %, 50/60 Hz 400 V + 6 % -10 %, 50/60 Hz
Output voltage:	40...210 V 60...380 V
Output current:	0,2...16 A
Output frequency:	50/100 Hz (50 Hz supply) 60/120 Hz (60 Hz supply)
Setpoint:	0...10 VDC, 0(4)...20 mA or potentiometer 10 kΩ
Enable:	24 VDC or contact
Status relay:	Changeover (250 V, 1 A)
Regulator:	P-I Regulator adjustable
Soft start:	0,1...5 sec
Amplitude regulation:	Sensor connection: for example using Type REOVIB SW 07
Operating temperature:	0...45 °C
Protection class:	IP 54

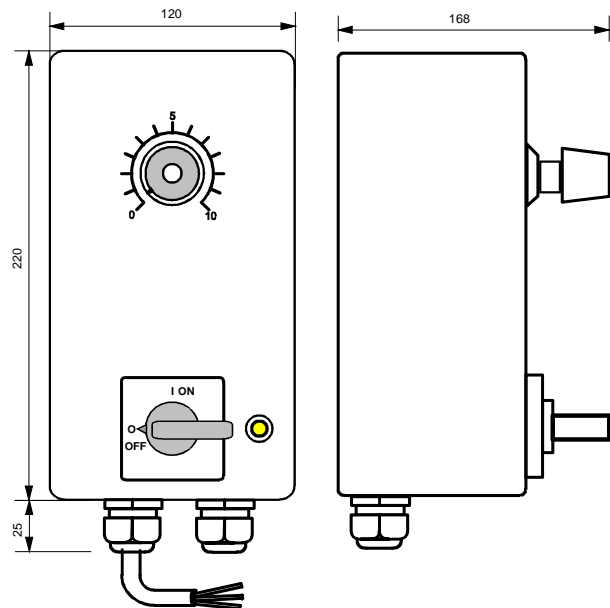

### REO ELEKTRONIK AG

Brühler Strasse 100

D-42657 Solingen

Phone +49-(0) 212-88 04-0

Fax +49-(0) 212-88 04-188

www.reo.de

email: main@reo.de

Subject to technical modifications without prior notice.

08/2004